

# **HomePNA2.0 Switch PLS8860 and PLS8861 User's Guide**

Rev. 1.5  
JUL 10,2003

# FCC Statement

This device complies with **part 15** of the FCC Rules.

Operation is subject to the following two conditions:

- (1) This device may not cause harmful interference, and
- (2) This device must accept any interference received, including interference that may cause undesired operation.

**NOTE:** This equipment has been tested and found to comply with the limits for a Class B digital device, pursuant to Part 15 of the FCC Rules. These limits are designed to provide reasonable protection against harmful interference in a residential installation. This equipment generates, uses, and can radiate radio frequency energy and, if not installed and used in accordance with the instructions, may cause harmful interference to radio communications. However, there is no guarantee that interference will not occur in a particular installation. If this equipment does cause harmful interference to radio or television reception, which can be determined by turning the equipment off and on, the user is encouraged to correct the interference by one or more of the following measures:

- Reorient or relocate the receiving antenna.
- Increase the separation between the equipment and receiver.
- Connect the equipment into an outlet on a circuit different from that to which the receiver is connected.
- Consult the dealer or an experienced radio/TV technician for help

This equipment complies with 47 CFR **part 68** Rules.

On the bottom of this equipment is label that contains, among other information, the ACTA registration Number and Ringer equipment Number (REN) for the equipment. If requested, this information must be given to the Telephone Company.

The REN is useful to determine the quantity of devices you may connect to your telephone line and still have those entire devices ring when your telephone number is called. In most, but not all areas, the sum of the REN's of all devices connected to one line should not exceed five (5.0). To be certain of the number of devices you're local telephone company to determine the maximum REN for you're calling area. If your telephone equipment cause harm to the telephone network, the Telephone Company may discontinue your service temporarily. If possible, they will notify you in advance. But is advance notice isn't practical; you will be informed of your right to file a complaint with the ACTA.

Your telephone company may changes in its facilities, equipment, operations or procedures that could affect the proper functioning of your equipment. If they do, you will be notified in advance to given you and opportunity to maintain uninterrupted telephone service. If you experience trouble with this telephone equipment, please contact the following address and phone number for information on obtaining service or repairs. The telephone company may ask that you disconnect this equipment from the network until the problem has been corrected or until you are sure that the equipment is not malfunctioning. This equipment may not be used on coin service provide by the telephone company. Connection to party lines is subject to state tariffs.

**CAUTION:** Any changes or modifications not expressly approved by the party responsible for compliance could void the user's authority to operate the equipment.

---

# **TABLE OF CONTENTS**

<b>INTRODUCTION</b>	<b>1</b>
<b>Features</b>	<b>1</b>
<b>INSTALLATION</b>	<b>2</b>
<b>Packing List</b>	<b>2</b>
<b>Front Panel</b>	<b>2</b>
Connectors	2
LED Indicators	2
<b>Connecting the Cables</b>	<b>2</b>
<b>Verification</b>	<b>4</b>
<b>CONFIGURATION</b>	<b>6</b>
<b>Switch Operating Mode</b>	<b>6</b>
<b>About Configuration Utility</b>	<b>6</b>
<b>Easy Version Utility</b>	<b>6</b>
<b>Full Function Utility</b>	<b>7</b>
Access Management Domain	7
Add Switch as Domain Member	8
Access Switch via Local Configuration	8
Add Switch	9
Access Switch via Remote Configuration	11
<b>Use Configuration Utility (Easy or Full-Function)</b>	<b>12</b>
Getting Started	12
Setting Preferences	13
Showing Icon	17
<b>CONFIGURATION UTILITY</b>	
<b>FUNCTIONS</b>	<b>18</b>
<b>Management</b>	<b>18</b>
<b>Member</b>	<b>19</b>
<b>Search</b>	<b>20</b>

<b>Upgrade</b>	<b>20</b>
<b>Restore</b>	<b>20</b>
<b>Backup</b>	<b>20</b>
<b>Report</b>	<b>21</b>
<b>Mode</b>	<b>21</b>
<b>Help</b>	<b>21</b>
<b><i>ADVANCED FEATURES</i></b>	<b>22</b>
<b>Port-Based VLAN</b>	<b>22</b>
Default VLAN and Remote Configuration	22
Close VLAN	22
More VLAN	23
<b>SNMP</b>	<b>23</b>
<b>HomePNA port Setting</b>	<b>25</b>
<b><i>FIRMWARE UPGRADE</i></b>	<b>26</b>
<b><i>SPECIFICATIONS</i></b>	<b>28</b>





# 1

---

## **INTRODUCTION**

This chapter describes the features of your HomePNA2.0 switch PLS8860, and HomePNA2.0 switch with Remote Management Unit(refer as **RMU**) PLS8861.

### **Features**

- ◆ 14-Port 10Mbps HomePNA2.0 Connection
- ◆ Two 10/100M Fast Ethernet Ports for Expansion or Link to Switch/Hub/Router
- ◆ Port-Based VLAN Security Support
- ◆ Supports Local Configuration via RS-232 Console Port
- ◆ Supports Remote Configuration via Telnet Protocol(PLS8861)
- ◆ Supports SNMP(PLS8861)
- ◆ 4M Bytes Fast Buffer Memory
- ◆ 1K MAC Address Table with MAC Address Filtering
- ◆ Store and Forward Switching Architecture
- ◆ Standard Rack-Mount 1U Size

# 2

## INSTALLATION

This chapter describes the installation procedure for your switch.

### Packing List

Your package should come with the equipment listed below. If any item is missed or damaged, notify your dealer immediately.

- ◆ One HomePNA Switch PLS8860 (or PLS8861).
- ◆ One External AC Power Cord.
- ◆ One RS-232 Console Cable (DB9-MiniDin8).
- ◆ One Cascaded Console Cable (MiniDin8-MiniDin8).
- ◆ One User's Guide.

### Front Panel

See the following Figure 1.



*Figure 1 Front panel of PLS8860/PLS8861*

### Connectors

1. 1 to 14: Fourteen HomePNA ports with dual-row RJ-45 connector labeled '1' to '14'. Each HomePNA port has one 'Line' connector (upper row) and one 'Terminal' connector (bottom row).
2. E1, E2: These two Ethernet ports are used to cascade with other PLS8860 (PLS8861) or standard Ethernet Switch/Hub. See the following section "Connecting the Cables" in this Chapter.
3. Console IN/OUT: The console IN port may connect to the serial COM port of PC for local configuration. You can cascade the console IN/OUT port through a lot of switches for configuration. See "Connecting the Cables".

### LED Indicators

1. PWR: Lighting up when power on.
2. Link/Act (1 to 14): Each led represents the responding HomePNA port. Flashing when there is any data traffic.
3. Link/Act (E1, E2): Lighting up when the Ethernet link is active, and flashing when there is any data traffic.
4. ID: 7-segment led shows the switch ID.

### Connecting the Cables

The HomePNA 'Terminal' port (1 to 14) requires standard twisted phone wiring for user attached to the same phone line via the PNA adapter. And the HomePNA

'Line' port (1 to 14) connects to the PSTN/PABX for your original phones. The Ethernet port (E1 and E2) is unshielded twisted pair (UTP) 100Base-T cabling. All 16 ports work as a standard 16 ports Ethernet switch in the LAN (Local Area Network) environment. See Figure 2 for the cabling of single HomePNA switch PLS8860 or PLS8861.

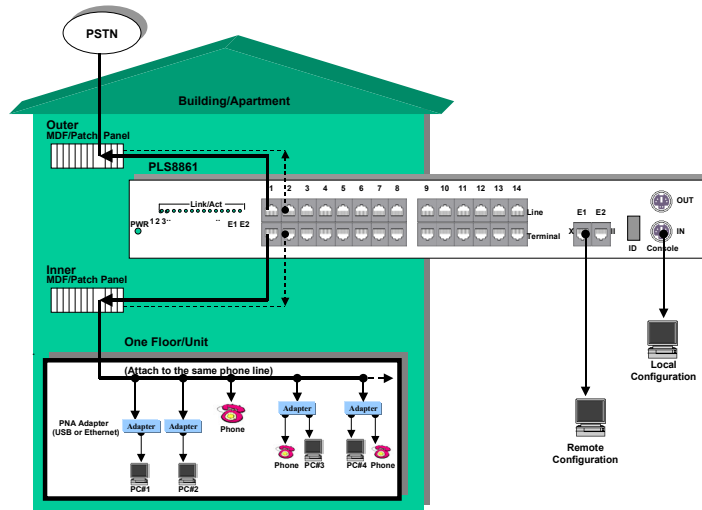

**Figure 2** Cabling of one PLS8860/PLS8861

You can stack more PLS8860s to accommodate more HomePNA users by cascading PLS8860's Ethernet port and Console port together. For example, connect two or three PLS8860 with Ethernet cable from one switch's E1 port (MDI-X connector) to the next switch's E2 port (MDI-II connector). And cascade their console port together for the configuration utility to configure all cascaded switches via one console port. See Figure 3 for the cabling of cascaded HomePNA switches for more details.

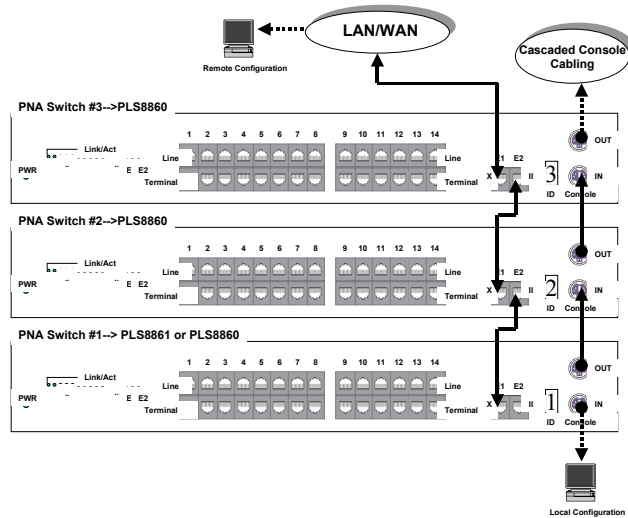

**Figure 3** Cabling of more PLS8860/PLS8861

The other way to stack more PLS8860s is applying Ethernet Switch that **supports Port-Based VLAN**. This connection can achieve maximum available bandwidth utilization for all users (max 10Mbps per user) if the Ethernet Switch supports Giga bit rate up-link trunk. Note that E1 port is up-link port of PLS8860/PLS8861. Also cascade their console port together for the configuration utility to configure all cascaded switches via one console port. See the following Figure 4,

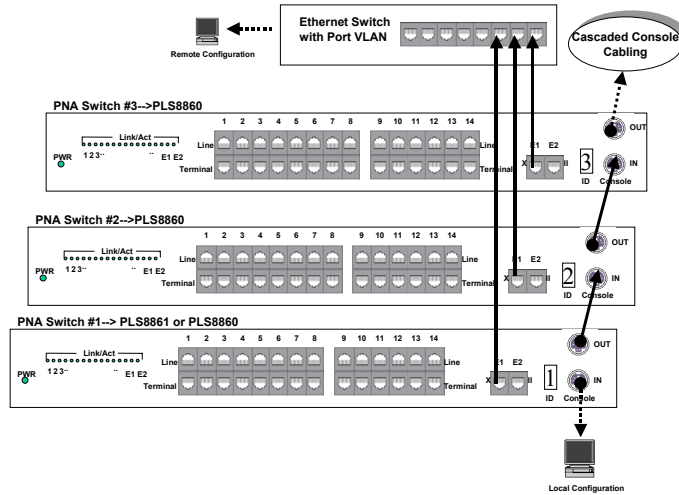

**Figure 4 Cabling of more PLS8860/PLS8861 by Ethernet Switch**

Note that in the stacking switch architecture as in Figure 3/Figure 4, the PNA switch ‘#1’ (ID is 1) **must be PLS8861** if you need remote configuration capability. And other switches except ‘#1’ must be PLS8860 (i.e. #2, #3... **are all PLS8860**). Else you can stack all PLS8860 switches as in Figure 3/Figure 4 without PLS8861 if you just need local configuration. The remote configuration function can only work with PLS8861. PLS8861 is made of one PLS8860 switch and one Remote Management Unit (RMU) inside.

**NOTE:** The 7-segment led shows the switch ID from ‘1’, ‘2’, ... to ‘9’ in a cascaded switch system. The dot (•) symbol shows on the 7-segment's right-bottom corner indicates that the switch ID will plus 10. The 10<sup>th</sup> cascaded switch ID will show ‘0.’, and 11<sup>th</sup> switch will be ‘1.’. The 19<sup>th</sup> switch ID is ‘9.’. If you cascaded more than 19 switches, the switch ID for the 19<sup>th</sup>, 20<sup>th</sup>, ... will always be ‘9.’.

## Verification

After you have finished the installation, you should use the configuration utility to access the switch through **Ethernet** link (remotely by PLS8861) or **Console** link (locally by PLS8860 or PLS8861) to verify the installation is completed. (See next Chapter for details).

**NOTE:** The factory default Port-Based VLAN setting doesn't allow the configuration utility to access the switch PLS8861 remotely through HomePNA port (1 to 14). Because the PLS8861's internal RMU is connected to E2 port, and only E1 and E2 are within the same VLAN group. **You should connect to E1**

**port of PLS8861 with Straight-Through Ethernet UTP cable (not Crossover cable) to your PC** and then access RMU through E1 port by default. You may modify the default VLAN setting to allow some HomePNA ports to access the PLS8861 remotely. (See VLAN in Chapter 5 for more details).

## CONFIGURATION

This chapter describes the configuration procedure for your switch.

### Switch Operating Mode

The switch system could be in one of the two operating modes: **Smart** mode and **Static** mode. Smart mode works as a standard Ethernet switch, the 14 PNA ports will learn MAC address automatically. The other--Static mode can only accept connection from the predefined user account. Each PNA port will audit the incoming packet based on the built-in static MAC entry in Static mode. The factory default is Smart mode, you may change the operating mode by the configuration utility.

### About Configuration Utility

The configuration utility is a graphical user interface tool runs on MS-Windows platform that helps you to configure and manage your HomePNA switch environment. There are two types of utility: **easy version utility** with simplified operation procedure to configure one switch system; the other is **full function utility** that can manage multiply switch systems. It helps to build up the connection topology of your HomePNA switch environment and to query or update the setting inside your switch system. The tool can also save the current connection topology or back up the switch setting information inside your HomePNA switch system as a file on your PC.

### Easy Version Utility

Execute the utility, choose the connecting path: **Local by Com** port(PLS8860/PLS8861) or **Remote by IP** address(PLS8861 only). Then login the switch directly with the factory default **Username/Password --'user1/root'**.

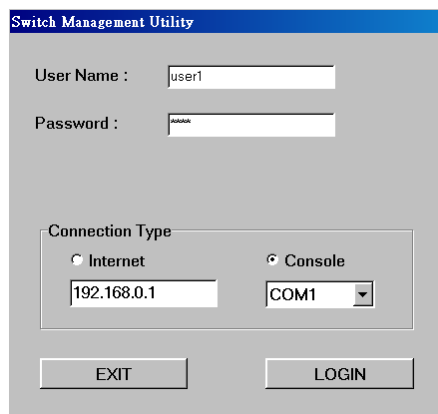

The screenshot shows a window titled "Switch Management Utility". It contains the following fields and controls:

- User Name :** A text input field containing "user1".
- Password :** A text input field containing "AAAAA".
- Connection Type:** A section with two radio buttons: "Internet" (unselected) and "Console" (selected).
- Under "Internet": A text input field containing "192.168.0.1".
- Under "Console": A dropdown menu showing "COM1".
- At the bottom: Two buttons labeled "EXIT" and "LOGIN".

You can now configure the connected switch system. You may refer the following "Full Function Utility" section for more detail or refer the later section entitled "Use Configuration Utility" directly from now on.

## Full Function Utility

Its purpose is to control the rights for the different managing user to configure a switch system within a predefined management domain.

### Access Management Domain

A management domain created by the domain supervisor (or say domain super user, domain administrator) may contain one or many switch system. The supervisor is the master manager within each domain and defines the tree-layer switch connection topology. The supervisor may grant rights to other managing users to control predefined switch system; these managing users help the supervisor to manage some switches with limited access rights. See the following example for more details.

### Create Domain

Execute the configuration utility will require you to login to a domain first. You need to create a new domain when you execute the utility program at the first time. For example, start the utility then click the 'New' button to create the domain 'TEST' with supervisor username 'super' and password 'test' as in the following figures.

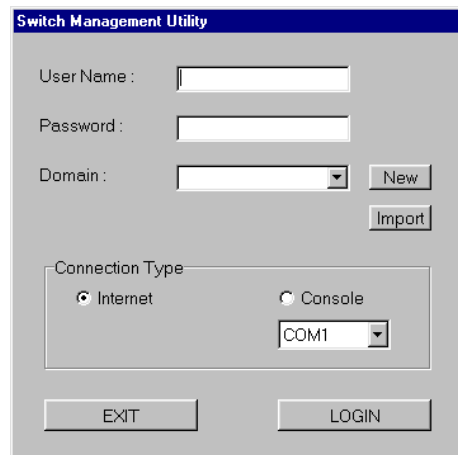

The screenshot shows the 'Switch Management Utility' window. It contains the following fields and controls:

- User Name :
- Password :
- Domain :  (with a dropdown arrow)
- Connection Type:
  - Internet
  - Console
  - COM1 (dropdown menu)
- 



The screenshot shows the 'Management' window. It contains the following fields and controls:

- Super User :
- Password :
- Confirm Password :
- Description :
- Domain :
-

Click button 'SAVE' in the above figure will store the domain 'TEST' configuration on your PC, then type in username 'super' and password 'test' to login the domain as supervisor. The following figure shows the main menu after you login the domain.

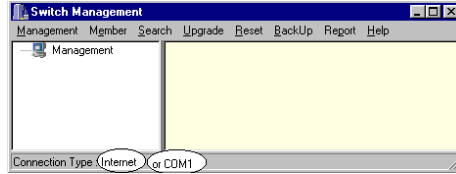

### Add Switch as Domain Member

You need to assign the switch (one switch or cascaded system) as a domain member before you can really connect and manage the switch within the domain. The utility will try to access and login the switch when it is being assigned to the domain at the first time. There are two ways to connect and access the switch system, **local configuration** and **remote configuration**. The remote configuration is only applied to the switch system with PLS8861 as the '#1' switch. (See Figure 2 and Figure 3 in Chapter 2).

### Access Switch via Local Configuration

To configure your PLS8860/PLS8861 switch system by local console, do the following:

1. Connect 'Console Cable' to front panel Console 'IN' connector and then connect the cable to PC's serial port, as COM1.
2. Execute the configuration utility on PC, choose 'Console' and the correct COM port in the field 'Connection Type'.
3. Login the domain as the supervisor. For example, login the domain 'TEST' with username 'super' and password 'test' as the following figure,

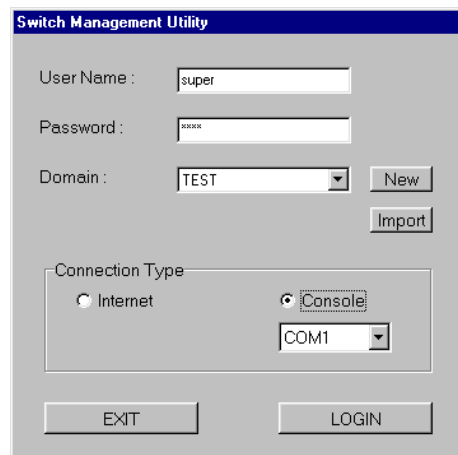

4. You can now access the main menu of the configuration utility after login.

**NOTE:** Always connects to '#1' switch for local configuration in a cascaded switch system. The '#1' switch is the configuration master for all other switches in a switch system.

## Add Switch

Click **'Member'** and choose **'Add'** function in the main menu of configuration utility,

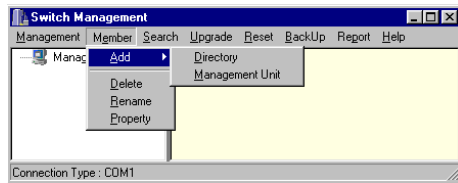

You may click **'Directory'** to extend one connection level as general tree-layer file structure, or click **'Management Unit'** to add one switch or cascaded switch system attached on current level as the file (node, leaf) to be managed. In the **'TEST'** domain example, we try to add a directory **'Location-A'** and a switch PLS8861 **'SW-1'** as a member. Typically the directory name joins the member name defines the **name string** which gives the identification of the switch. And this **ID** should be unique inside current domain. Add one switch will pop up the switch property window and you need to fill in the blank fields as the next figure.

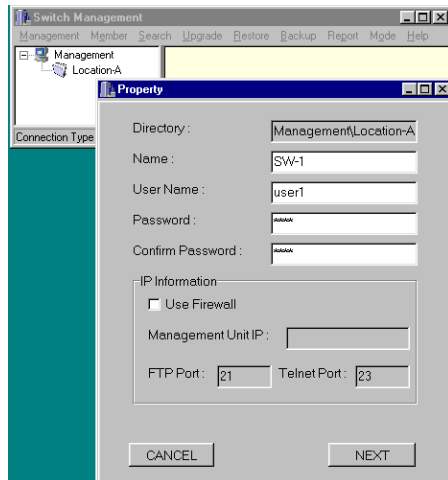

The directory naming **'Location-A'** and switch naming **'SW-1'** in current domain **'TEST'** defines your connecting topology; you can define different layering structure according to the real wiring architecture. The username and password in the above window are used to login the **'SW-1'** switch system.

**NOTE:** The IP information field in the above figure will be enabled when you add a switch member by remote configuration (i.e. login with connection type **'Internet'**). You may denote the IP address of your switch system. Or if the utility is allowed to pass through the firewall and access the switch system behind the firewall; you need the IP address of the firewall, and maybe you need to specify the different port number for **'Telnet/FTP'** to pass the firewall.

**NOTE:** The factory default **Username/Password** for PLS8861/PLS8860 is **'user1/root'**. You may change them in **'Member/Property'** window of configuration utility after you login successfully as the domain supervisor.

Click button 'Next' in the above property window will show the next security property window that control the access rights for all managing users (There is only one user--supervisor in our example now).

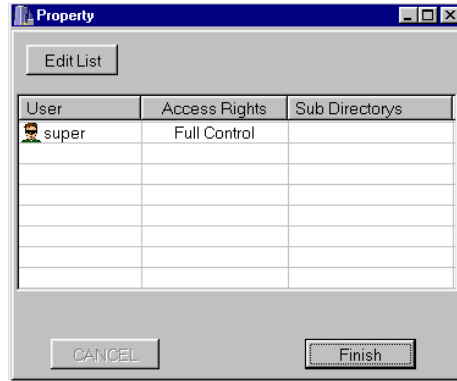

Click button 'Finish', then utility will try to connect 'SW-1' and to retrieve current setting inside the switch. These retrieved setting will be updated according to your previous configuration. The detail property window will pop out automatically and request you to confirm the configuration. Including System IP environment, SNMP and Security access rights control. Here's the Property/System and Property/SNMP windows in our example,

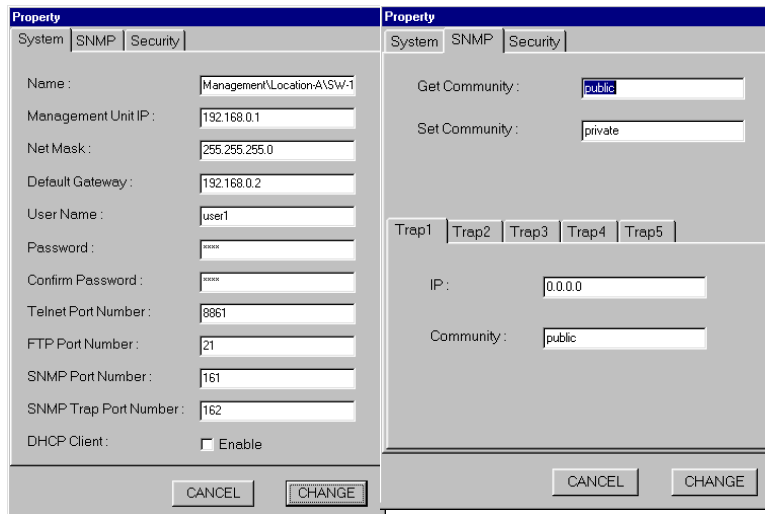

- Name:** the complete path to locate 'SW-1' in current domain
- IP:** the current IP address of your managed member--PLS8861 (the IP of RMU). It's a fixed IP if the DHCP Client is disabled or the IP obtained from DHCP Server when DHCP Client is enabled.
- Net Mask:** the subnet mask of IP LAN environment
- Default Gateway:** the Router/Gateway IP address for the WAN/LAN connectivity of the managed member
- User Name:** username to login the member
- Password:** password to login the member
- Confirm Password:** retype and confirm the login password.
- Telnet/FTP/SNMP/SNMP Trap Port Number:** the assigned port for the utility to access the managed member. The default port number Telnet:8861,

FTP:21, SNMP:161, SNMP Trap:162. The utility uses 'Telnet' for remote configuration and 'FTP' for remote firmware upgrading. The SNMP monitoring utility queries the managed agent through 'SNMP' port and intercepts any trap on 'SNMP Trap' port.

**DHCP Client:** Enable the RMU to obtain the 'IP', 'Net Mask' and 'Default Gateway' fields from DHCP Server.

The previous Property/SNMP window let you activate 'SNMP trap' operation, you can setup at most five hosts for receiving trap. Field 'IP' sets to '0.0.0.0' will be disabled. Please refer the section entitled 'SNMP' in Chapter 5 for more SNMP details.

Click button '**CHANGE**' to accept the configuration and store the setting into '**SW-1**'.

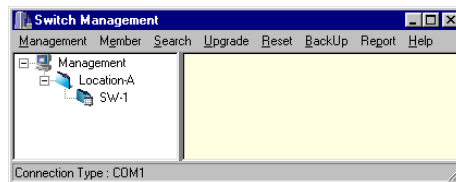

The above figure shows the PLS8861 switch '**SW-1**' has been assigned to domain '**TEST**' successfully.

**NOTE:** The detail property window is different for PLS8860.

## Access Switch via Remote Configuration

Only PLS8861 (contains RMU) supports the capability of remote configuration. The configuration utility communicates with your remote switch system by 'Telnet' protocol at port number '8861'. Make sure your PC supports 'TCP/IP' before you start the remote configuration.

1. Execute the configuration utility on PC, choose '**Internet**' in the field 'Connection Type'. Login the correct domain, as '**TEST**' for example. The 'Connection Type' in the bottom of next figure denotes '**Internet**' instead of '**COM1**' for remote configuration. Note that we just login and browse the connection topology within the domain, we don't make any connection to the switch '**SW-1**' yet.

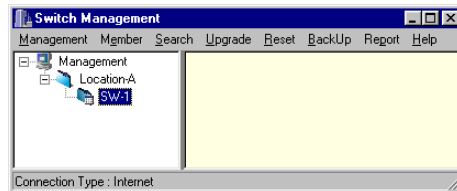

2. The factory default IP address is '**192.168.0.1**' and default subnet mask is '**255.255.255.0**' for the RMU if there is no DHCP Server. To access the switch with default IP, your PC should be within the same IP network as the switch PLS8861. That is, your PC's IP address should be as "192.168.0.xxx". For instance, you may connect one PC with the switch directly by one Ethernet cable between your PC's Ethernet adapter and switch's E1 port. And configures your PC's TCP/IP setting to fixed IP as "192.168.0.xxx", subnet

- mask as "255.255.255.0", disable DHCP option. Reboot your PC to access the switch via the configuration utility within the same "192.168.0.xxx" network.
3. Double click on 'SW-1' icon will try to login and connect the switch in our example.

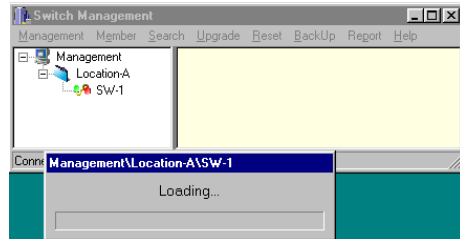

4. You can then modify the RMU's default IP address according to your own IP environment in 'Member/Property' window of configuration utility. Or the RMU can obtain IP address automatically by its DHCP Client if there exists any DHCP Server.

**NOTE:** The RMU of PLS8861 will reboot after the IP property has been modified. And current connection with old IP property will be terminated. You need to establish a new remote connection with the new IP to access the switch PLS8861.

**NOTE:** If the current connection of remote configuration is terminated abnormally, the system will wait about 3 to 5 minutes to recover. Then you can establish the new connection again.

## Use Configuration Utility (Easy or Full-Function)

The utility is similar to 'File Manager' in 'Microsoft Windows® System'. The main window contains the left sub-window for the items to be configured, and the right sub-window display the contents for the selected item. Double click your mouse on the item in the left window will pop out the corresponding item-window in the right side.

### Getting Started

1. Assume you have started the utility (local or remote), and have the rights to configure the switch in the selected domain (either you login as supervisor or have the access rights assigned by supervisor), login the domain successfully as in the following figure.

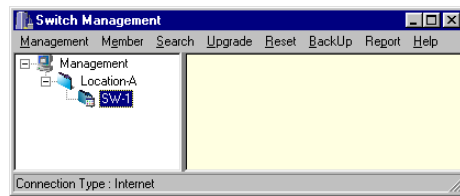

2. The above figure shows the domain contains only one switch system 'SW-1'. Double click on the 'SW-1' icon will 'Connect' to 'SW-1' and 'Load' the internal configuration from 'SW-1'. It may takes a few seconds for the utility to retrieve the current setting of the connected switch system.

3. The next figure shows the switch system 'SW-1' contains only one switch ('Switch1'). If the system is cascaded with many switches, you should see 'Switch2', 'Switch3', ... in the left window. To expand a level of the switch hierarchy, click on the plus (+) symbol next to that level. The following figure shows the expanded switch level.

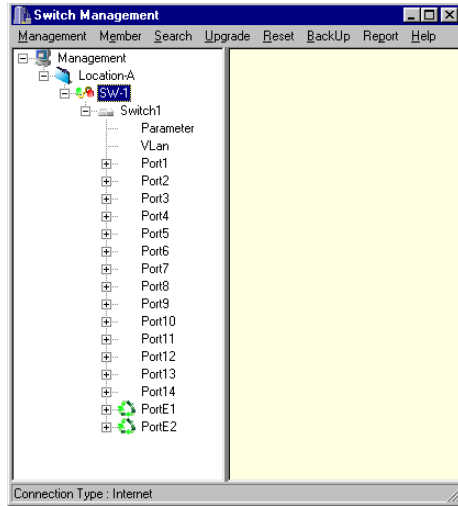

4. Examine, and change if necessary, the items in 'Switch1':

**Parameter**

Global parameters for all 16 ports

**VLAN**

Virtual LAN configuration for all 16 ports

**Environment**

Monitor the switch environmental status

**Port1 to Port14**

Related HomePNA port setting

**PortE1, PortE2**

Related Fast Ethernet port setting

## Setting Preferences

This section describes and explains how to set the individual item.

◆ **Parameter**

**MAC age:** range 1~256 sec, setup the learned MAC address lifetime in E1 and E2 port. The learned MAC entry will be flushed while the port doesn't receive any Ethernet packet again with the same MAC source within the period.

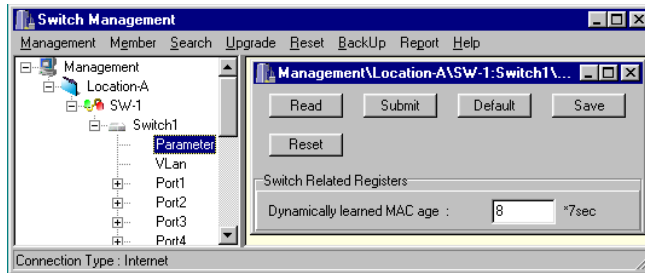

Fast Ethernet port (E1 and E2) in HomePNA switch has featured the MAC address auto-learning capability as standard Ethernet switch. And other HomePNA port (1 to 14) works the same way in Smart mode. In Static mode, the switch will audit the incoming packet and decide to accept it or not based on the presetting MAC address table in each port. The HomePNA port will reject any packet with unauthorized source MAC address in Static mode.

**NOTE:** The following operation buttons work the same way for all windows in the configuration utility.

**Read**-- read current setting from the switch.

**Submit and Save**-- Submit: send the new setting into the switch register, the switch behavior will change immediately.

Save: save the internal register setting into switch 'EEPROM'. After power off then power on again, the switch will keep on this saved setting always.

**Default**-- reset to factory default value, but not save into the switch until you issue 'Submit and Save'.

**Reset**-- reset the related part of switch. Press the 'Reset' button in 'Parameter' window will reset the whole switch, press the 'Reset' button in each port window will reset the corresponding port only.

**Delete**—this button appears in 'UserInfo' window of Static mode, it deletes the selected user information in the window, then press 'Submit and Save' to delete the user information in the switch.

**Delete All**—this button appears in 'UserInfo' window of Static mode, it deletes all user information in the window, then press 'Submit and Save' to delete the user information in the switch.

◆ **VLAN**

Refer to Figure 3 in Chapter 2, the cascaded Ethernet link acts as a traffic trunk to aggregate all HomePNA port traffic. The straightforward VLAN configuration should let each HomePNA port (1 to 14) can communicate with the trunk for LAN/WAN connectivity, but can't communicate with each other directly. Only the ports within the same VLAN group can access each other directly.

See the **default** Port-Based VLAN setting in the following figure as an example:

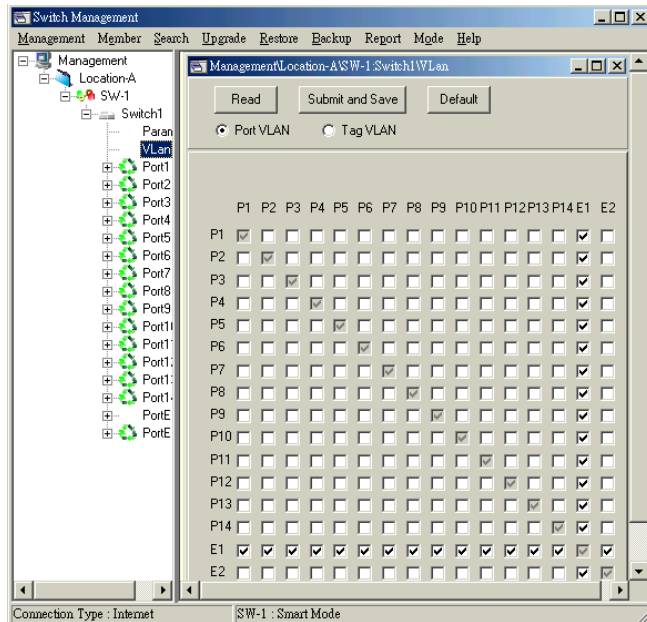

The above window indicates that each HomePNA port (1 to 14) is grouped with PortE1, i.e. within the same VLAN. PortE1 and PortE2 are grouped in one VLAN. In this configuration, PortE1 acts as up-link port; PortE2 gathers the traffic from other cascaded switch up-link port. The following figure shows the data flow of default Port-Based VLAN groups in one switch.

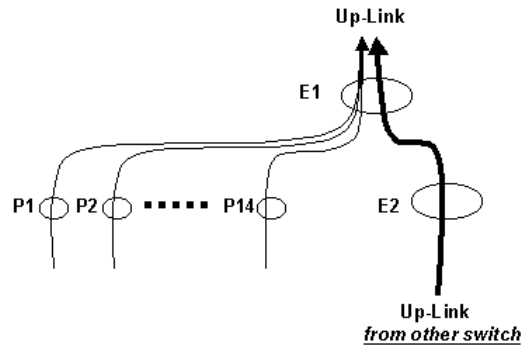

You can refer this figure as the role of ‘PNA Switch #2’ or ‘PNA Switch #3’ in Chapter 2 Figure 3. Please refer VLAN in Chapter 5 for more details.

◆ **Environment**

To monitor operation temperature, power voltage and fan tachometer condition,

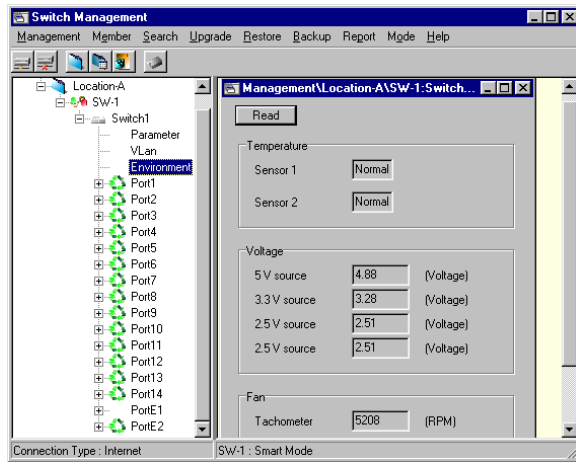

◆ **Port1~Port14**

Use 'Setting' window to adjust some communication factors for each HomePNA port. These factors including transmit priority, line speed, etc. Next figure shows the default 'Setting' window:

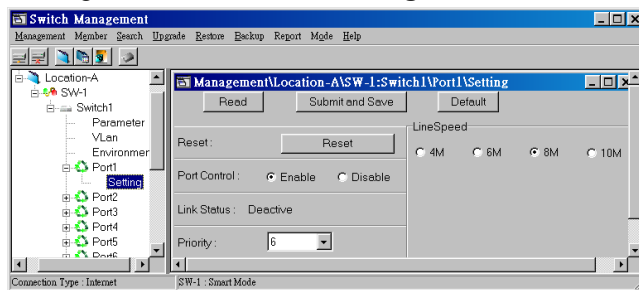

In the field application, every phone line wiring condition is different. The factory default setting should have good performance in all environments. You may try to pursue the best transmission performance, see 'Chapter 5 Advanced Features' to adjust HomePNA port's attribute to improve the connection quality.

In Smart mode, user can access the HomePNA switch via PNA adapter, it's 'plug-and-play'. In Static mode, you have to open an account for the user to access the switch in 'UserInfo' window. The PNA adapter's MAC address is the key to pass the switch MAC address filter in Static mode. For example, registered user with TEL '123456' can access Port1 in the following setting.

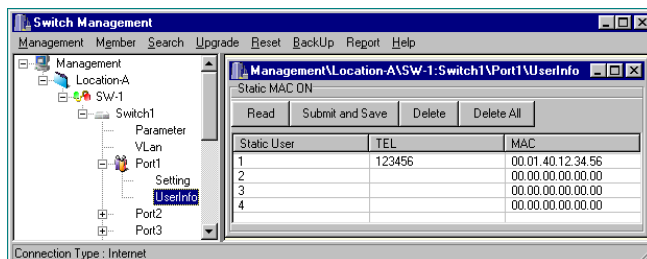

There are as many as 4 users can attach on the same HomePNA port via one pair phone line in Static mode, as shows in the above figure.

**NOTE:** The field 'TEL' in 'UserInfo' window could be any alphanumeric text up to 12 characters and is used to identify the registered user. For example, you may register user's name in this field.

◆ **PortE1,PortE2**

The state of PortE1 and PortE2 will always show 'ENABLE' as in the following figure.

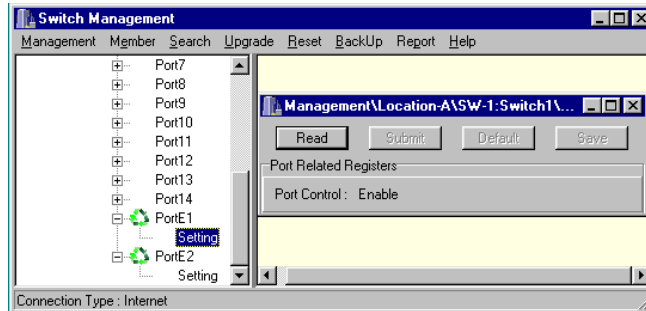

## Showing Icon

This section explains the meaning of each showing icon in the utility.



Management **Directory** Icon



Management **Unit** Icon



Current Switch **Port** is in Auto-MAC learning mode



Current Switch **Port** contains registered user information



Management **Unit** is being connected (try to access and login)



Management **Unit** is connected (login successfully)

## CONFIGURATION UTILITY

### FUNCTIONS

This chapter describes the functions in configuration utility. The function of each item in main menu is described in details in the sections below.

### Management

Management function can control the state of selected member and the managing user account. Including the member connection status, access rights for different managing user, login username/password for each user within current domain. See the following items in **Management** menu:

◆ **User**

Setup other managing user account, including Add/Delete/Property sub-function if you login the domain as supervisor. Or you can only change the password if you login the domain as normal managing user. For example, the supervisor may add one managing user 'A' with password 'a' as the following figure.

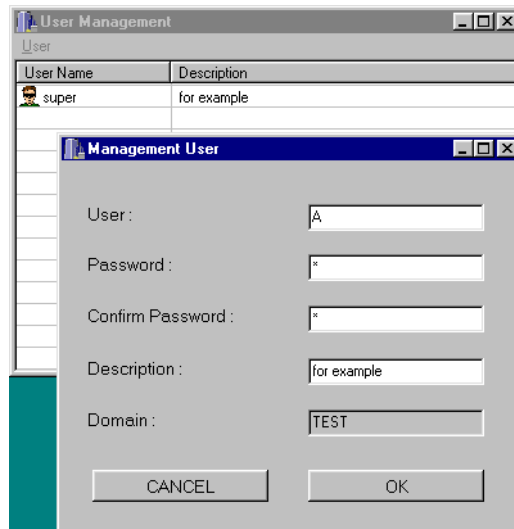

◆ **Connect**

Connect and login the selected switch system within current domain.

◆ **Load**

Load all setting form the connected switch system into the configuration utility.

◆ **Submit and Save**

Store all setting in the configuration into the connected switch system and save into 'EEPROM'. The switch will keep on current setting whenever it's powered up.

- ◆ **Reboot**  
Reboot the RMU inside the connected switch system or reboot the switch itself only.
- ◆ **Disconnect**  
Disconnect and logout the selected switch system within current domain.
- ◆ **Save**  
Save current domain setting and connection topology in the configuration utility to a file on your PC. The saved domain file has the filename extension '.smp'. You may backup the saved file for current domain setting by the configuration utility 'BackuUp' function.
- ◆ **Exit**  
Exit configuration utility program.

## Member

This function is open to domain supervisor. Only supervisor can configure member property in current domain. Member means the 'Directory' or the 'Management Unit' in configuration utility.

- ◆ **Add**  
Add one new member into current domain.
- ◆ **Delete**  
Remove the selected member from current domain.
- ◆ **Rename**  
Renaming the selected member.
- ◆ **Property**  
Configure the properties of selected member. There are three different property windows--System, SNMP and Security. For instance, select member 'SW-1' as in our previous 'TEST' domain example, then choose Property/Security window and click button 'Edit List'. The next figure shows the way to add one managing user 'A' that has the rights to access member 'SW-1'.

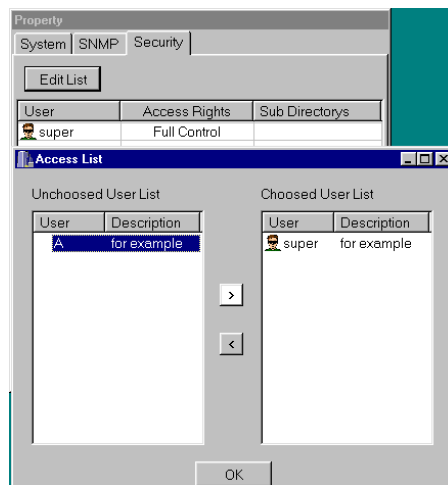

Click arrow sign '>' and button '**OK**'. You can login the '**TEST**' domain later with username '**A**' and password '**a**' as the managing user '**A**'. The access rights for user '**A**' is limited to member '**SW-1**' within domain '**TEST**'.

**NOTE:** Different property windows could be displayed depends on the selected member type. For example, the type of your member is 'Directory' or 'Management Unit'; the type of your master configuration switch (switch ID #1) is PLS8860 or PLS8861, as in Chapter 2 Figure 3.

## Search

Use to search and identify a registered user in selected switch system.

- ◆ **MAC**  
To search all 'UserInfo' tables within each port of switch for the matched MAC address in current switch system. Key in 6 bytes MAC address and separate by dot (.) char as '**00.60.6E.00.00.06**'.
- ◆ **TEL**  
To search all 'UserInfo' tables within each port of switch for the matched telephone number in current switch system.

## Upgrade

Upgrade the selected cascaded PLS8860's switch firmware or upgrade the selected cascaded PLS8861+PLS8860's switch firmware and PLS8861's RMU firmware. Refer Chapter 6 for more details.

## Restore

- ◆ **Switch Default Setting**  
Restore all settings except 'UserInfo' in the selected switch system to factory default setting. Setting of 'UserInfo' will be unchanged.
- ◆ **Switch Information from File**  
Restore all settings including 'UserInfo' in the selected switch system from a backup file. The backup file has the default filename extension '**.si**'

## Backup

- ◆ **Domain**  
Back up current domain configuration to a file with filename extension '**.smp**'. In case the original domain configuration file is destroyed, you may restore the domain configuration file and still login the domain. To restore the backup-up domain file, click button '**Import**' in the login window of configuration utility.
- ◆ **Switch Information**  
Back up all setting and 'UserInfo' in the selected switch system to a file with filename extension '**.si**'.

## Report

- ◆ **Switch UserInfo**

Print all 'UserInfo' data in the selected switch system to a printer or to a file (file format \*.TXT, \*.CSV, \*.HTM...).

## Mode

Change the operating mode of connected switch system to Smart mode (default) or Static mode. Switch will reboot after mode is changed.

## Help

Some version information

## ADVANCED FEATURES

This chapter describes some of the advanced features offered by your switch.

### Port-Based VLAN

The main purpose of VLAN is security, to prevent HomePNA user to access each other directly in the switch system.

#### Default VLAN and Remote Configuration

The default Port-Based VLAN configuration in the switch PLS8860/PLS8861 allows each HomePNA user to group with PortE1 only. For each HomePNA user, to access the main Ethernet trunk E1 is allowed, to access other user (1 to 14, E2) is forbidden. The default VLAN setting doesn't allow user attached on HomePNA port (1 to 14) to access the switch PLS8861 for remote configuration. Because PLS8861's RMU is connected to PortE2, and HomePNA port (1 to 14) and PortE2 aren't within the same VLAN group. Remote configuration can access switch PLS8861 through Ethernet trunk on PortE1 (PortE1 and PortE2 are the same group), while local configuration for PLS8860/PLS8861 is unrelated with VLAN setting.

You may modify the default VLAN setting to allow one or more HomePNA users to access the PLS8861 for remote configuration. Be careful not to isolate PortE2 in the VLAN setting, if PortE2 is the single VLAN group (neither P1 to P14 nor E1 can access E2), you can only do the local configuration.

The following VLAN setting figure opens one path for user on Port1 to do remote configuration by combining Port1 and PortE2 the same VLAN group:

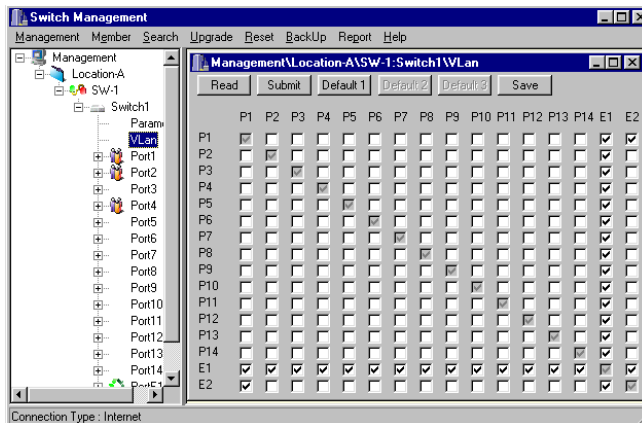

#### Close VLAN

If you wish to get ride of the VLAN restriction, users locate in the same LAN can access each other freely and make the switch work as a standard switch. You should group all users together as the following figure:

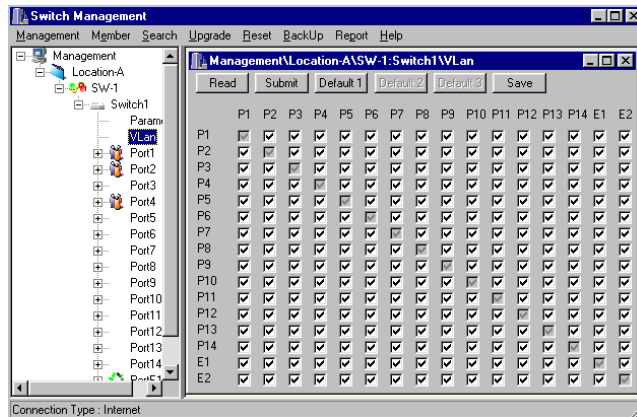

## More VLAN

In addition to the default VLAN setting, the following figure shows that HomePNA users on Port1, Port2, and Port3 are grouped as the same LAN. These users can communicate with each other and can access PortE1 of the main Ethernet trunk.

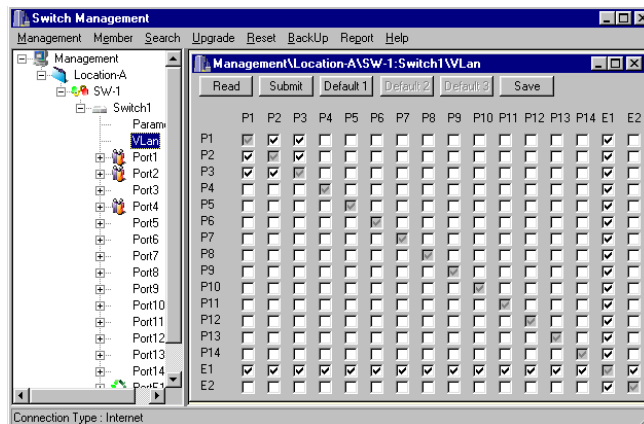

## SNMP

Only the switch system contains PLS8861 supports SNMP. The SNMP **Agent** inside PLS8861 is setting to read-only mode for monitoring the switch system and for reporting the requested SNMP data to the SNMP **Manager**. That is, the agent supports standard SNMP operations as 'GET' and 'TRAP', but 'SET' operation is restricted. You may need the accompanying proprietary **MIB file** for some popular SNMP/MIB manager software to manage the switch system. Or to integrate the PLS8861 switch system into your original SNMP management system by this specific MIB file.

We also provide the specific SNMP monitor utility (a simple SNMP manager) for the PLS8861 switch system. This SNMP utility is the customized software to monitor the SNMP states and events for the assigned switch systems through standard SNMP operations. Execute the SNMP utility, the next figure shows the main menu,

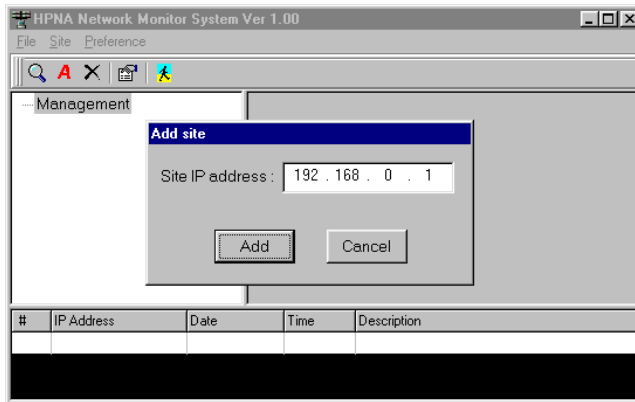

Choose 'Site/Add' function to add one switch system. For example, add site with IP address '192.168.0.1' within the 'TEST' domain. The SNMP utility will try to connect the switch when it is added. Then double click on 'SW-1' icon will retrieve the SNMP data for this SNMP monitor utility. As shows in the following figure,

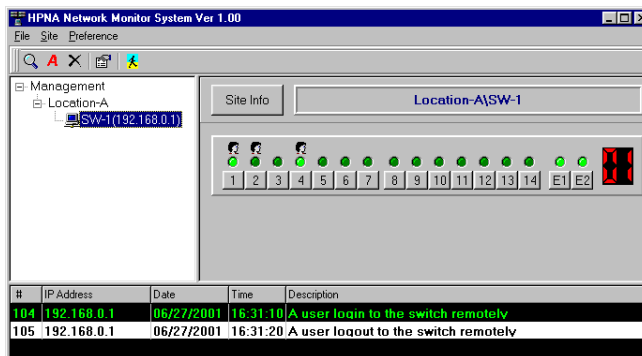

The left side window in the above figure shows the connection topology -- there is only one switch 'SW-1' in the selected system. The right side window displays the link status of each port -- Port1, Port4, PortE1 and PortE2 are link activated; Port1, Port2, and Port4 contain registered user info. The bottom window captures the events -- Trap number 104 and 105, Trap Source IP '192.168.0.1', Trap Date, Trap Time, and Trap Description. To enable this trap capturing function in SNMP utility, you need to open the destined Trap IP toward the SNMP utility in the configuration utility 'Property/SNMP' window of 'SW-1', please refer Chapter 3, 'Add Switch' sub-section.

Click the button on each port in the above figure will list the detail information about current port. For example, the following figure shows the button on Port1 has been pressed,

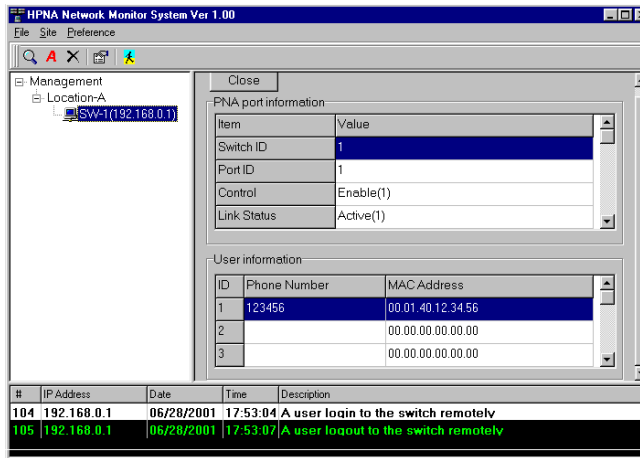

Note the 'Community Name' of SNMP monitor utility (set in the field 'Community' of 'Preference/General' window) must be identical to the 'GET' and 'TRAP' community inside each managed member (set by the configuration utility in the 'Member/Property/SNMP' window). Each SNMP manager must indicate the name of the community it belongs in all 'GET' and 'TRAP' operations. The community name could be unique to allow set of SNMP managers to access to the agent. The default 'GET' and 'TRAP' community name of PLS8861 is **'public'**.

## HomePNA port Setting

This section describes the items in the 'Setting' window in more details. As shows in the following figure:

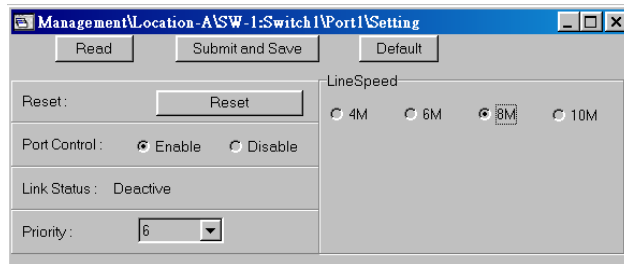

- ◆ **Reset**  
Reset current HomePNA port.
- ◆ **Port Control**  
To disable or enable current port. The disabled port will be shut down.
- ◆ **Link Status**  
It is an indicator to show the link is activated or not.
- ◆ **Priority**  
Range 0~7, select the traffic priority of current port, '7' is the highest priority level and '0' is lowest.
- ◆ **Line Speed**  
Select speed from 4Mbps to 10Mbps, please select low speed for reliable transmission if the phone line quality is not so good. Otherwise, the performance may be degraded. The factory default is 8Mbps.

## FIRMWARE UPGRADE

This chapter describes the procedures to update firmware in PLS8860 and PLS8861.

1. Use configuration utility to connect and login your switch system by Local configuration or Remote configuration. Choose item 'Upgrade' from the main menu, then click 'Firmware'. It will pop out the firmware version window. The window shows **Management** firmware and **Switch** firmware for PLS8861 as the following figure. For PLS8860, the window will display **Switch** firmware only.

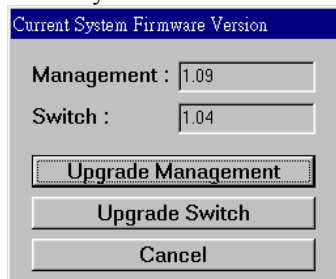

2. The procedures for 'Upgrade Management' and 'Upgrade Switch' are similar. Here we only describe the procedures for 'Upgrade Management'. Click button 'Upgrade Management' (or 'Upgrade Switch') to start upgrade. You will be prompted to input the new firmware.

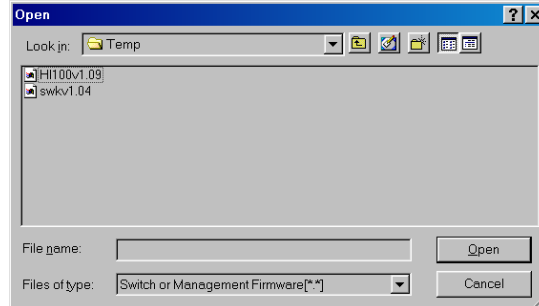

3. For example, select the new firmware "HL200Vx.xx" to upgrade your Management firmware. The next dialog window will ask you to confirm the operation.

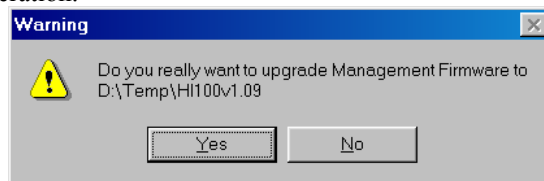

4. Click button 'Yes' if you want to proceed.

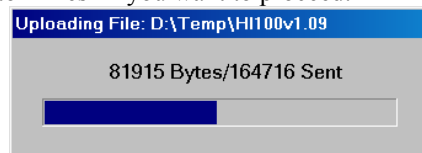

5. When the uploading is completed, the switch system will reboot.

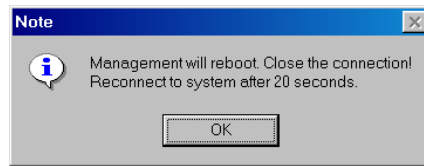

6. Press 'OK' and wait switch system to reboot. It takes about 20 to 40 seconds for 'Upgrade Management' and 2 minutes for 'Upgrade Switch'. Then the configuration utility will reconnect the switch system and will check the newest firmware version inside the switch system.

---

## **SPECIFICATIONS**

### **NETWORK INTERFACE**

- HomePNA2.0 10.0Mbps Compliant
- IEEE 802.3u 100M Fast Ethernet
- IEEE 802.3 10M Ethernet
- 10/100Mbps Auto-Negotiation Support
- Port-Based VLAN Support

### **NETWORK MANAGEMENT**

- Console Port: Mini-DIN (Locally)
- Windows Based Network Management Utility
- Remote Network Management (Via Internet or Ethernet Port, by Telnet Protocol)
- SNMP support
- Password for Access Protection
- Data Rate Adjustment of PNA Port
- Port Enable/Disable
- Terminal ID Filtering
- F/W Upgradeable

### **CONNECTORS**

- Ethernet: 2, RJ45 Jack
- HomePNA Port: 14 Ports, Two RJ45 per Port, One for HPNA, Another for Phone-line Bypass
- Console Port: 8-Pin Mini-DIN Jack

## **INDICATOR**

- Power
- HomePNA Activity
- Ethernet Link/Activity
- Mux ID Display (7-segment LED, to identify a mux by numbering in a cascaded system)

## **TERMINAL DEVICES**

- USB Adapter
- Ethernet/PNA Bridge

## **POWER REQUIREMENT**

- Internal Switching Power Supply
- Full Range 100 – 240 VAC, 50/60Hz
- Power Consumption : < 40 Watts

## **ENVIRONMENTAL CONDITION**

- Operation: 0 – 40 °C (32 – 104 °F)
- Storage : -10 – 65 °C (14 – 149 °F)
- Humidity : 10% - 95% Non-condensing

## **PHYSICALS**

- Dimensions: 445 x 190 x 40 mm
- Weight: 3.5 kg